

mobile

Conveyors

T - Type

The double hinged boom of the T-Type pivots on two sets of hydraulic rams to make the machine suitable for working from ground level or off a raised loading dock.

The TC/33, shown, has a telescopic boom for added flexibility and reach, while the T20 and T26 have a fixed length boom.

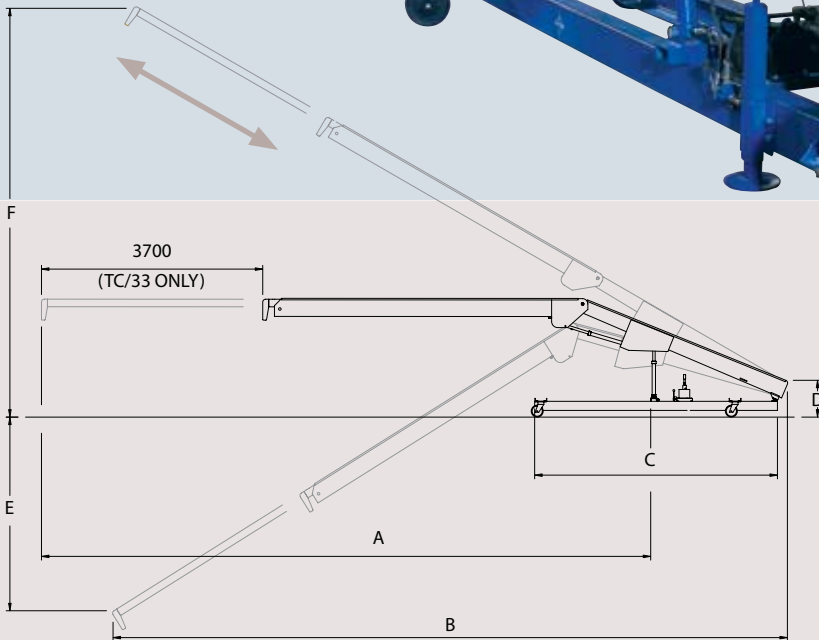
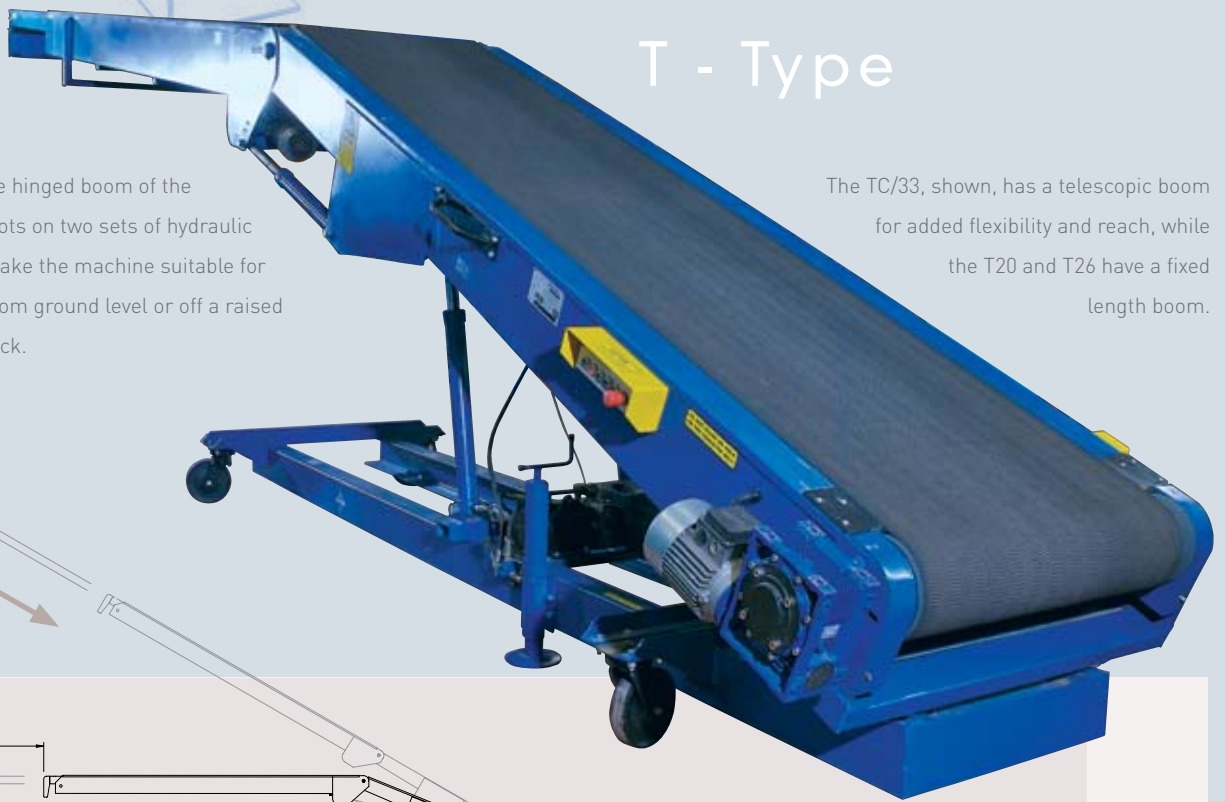

General Dimensions (mm)

	T20	T26	TC/33
REACH INTO VEHICLE (A)	6100	8000	10000
MINIMUM LENGTH (B)	8200	10000	8200
CHASSIS LENGTH (C)	3050	4060	4060
LOADING HEIGHT (D)	600	600	600
MINIMUM DELIVERY HEIGHT BELOW GROUND LEVEL	1300	2200	3500
MAXIMUM DELIVERY HEIGHT	4900	5800	6700

Additional dimensions for all models: Overall width at front wheels 1145mm. Overall width at delivery end 820mm. Overall width at belt power unit 1045mm.