

The Newland Glassveyor allows sealed double glazed units to cure as they travel along the conveyor from the bonding process to the despatch vehicle.

Slats are manufactured from specially formed plated steel with integral plastic bearers for the glass. Removable wooden dowels fitted to the slats support the glazed units in an upright position. Slow speed together with soft start and stop features, prevent sharp movement, eliminating product breakage.

# Glassveyor



# Trucklift

The Trucklift is a robust moveable tail lift platform for loading or unloading hand trucks and roll pallets.

The side mounted lifting gear means the operator has only to push the load up on to a platform 56mm high.

Bridging plates are fitted at either end of the platform to allow goods to be wheeled directly into or out of the vehicle.

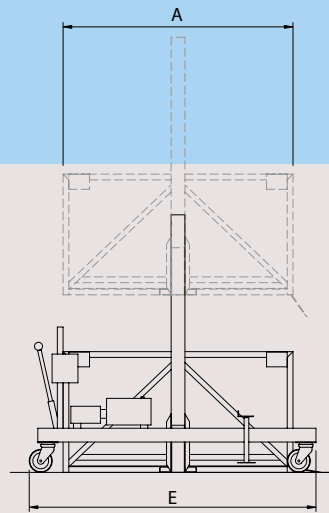
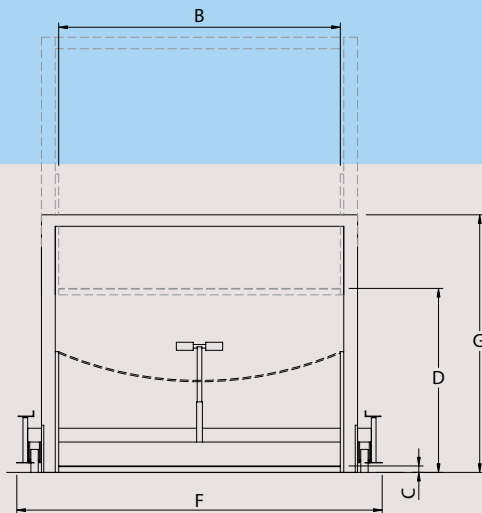

General Dimensions (mm) (Alternative machine dimensions also available)

	1 PALLET - 2 CAGE	2 PALLET - 4 CAGE	4 PALLET - 6 CAGE
<b>PLATFORM DEPTH (A)</b>	1850	2000	2550
<b>PLATFORM WIDTH (B)</b>	1500	2450	2450
<b>LOWERED HEIGHT (C)</b>	<b>2000KG LIFT</b> 56	56	56
	<b>3000KG LIFT</b> 56	56	56
	<b>DRIVE THROUGH MODEL</b> 106	106	106
<b>ELEVATED HEIGHT (D)</b>	1600	1600	1600
<b>OVERALL LENGTH +200 (E)</b>	2070	2220	2770
<b>OVERALL WIDTH (F)</b>	2240	3190	3190
<b>OVERALL HEIGHT (G)</b>	2240	2240	2240

Speed of elevation: 2000kg lift - 85mm/sec  
3000kg lift - 50mm/sec.